

DISPLAY CASES

Ambient Counter

MILLROCK



FEATURES

- ◆ **Curved Front Glass** - Unobstructed product view, Ez-Open™ bottom hinge
- ◆ **Lights For Every Shelf** - 3 Slim-line fluorescent fixtures illuminate all products, no shadows & great visibility, light shield & impact sleeve included
- ◆ **Any base Finish** - select any standard color, pattern or wood grain plastic laminate
- ◆ **Glass Rear Doors** - Tempered glass, bypass sliding, easy close & lift out (24" model has hinged glass rear door)
- ◆ **Wire Shelves** - (2) tiers of white epoxy coated shelving
- ◆ **Durable Top** - Stainless steel work/display deck
- ◆ **Bottom Shelf** - White laminate for brilliant display
- ◆ **Easy to Clean** - Ez-Open™ Tilting front glass, removable side glass & rear doors
- ◆ **Plug & 8' Cord Included** - 110v. Plug in and start selling!
- ◆ **Meets All Electrical & Sanitation Requirements for USA & Canada** including CSA, ETL, NSF, UL, & CRMA. Certified by CSA & ETL.
- ◆ **Superior Warranty** - 1 year parts and labor

Countertop Elegance

MILLROCK's Ambient Counter Display Case provides top notch display for cookies, biscotti, bagels, muffins, scones, non-dairy cakes, and other non-refrigerated snacks. The Ambient Counter Increases your profit ability boosting average ticket sales with impulse items right up front on your existing counter.

Small but powerful, the Millrock Ambient Counter is packed with quality features usually found only in full-size showcases.

Three display surfaces maximize capacity and assure exceptional product presentation. Tempered glass surround gives customers unobstructed view to the selection. Lights on every shelf assure all products are well lit. Sliding rear doors give ample access for operators to service customers and hinged front glass makes cleaning easy to keep your case looking sharp. Durable stainless steel top surface provides additional valuable display area. The base is laminated inside and out in the color and pattern of your choice at no extra cost for a custom look to match your store's interior design. Choice of three sizes gives you additional options for store layout and capacity. Unlike full-size cases, adding impulse countertop sales to your store is easy...just set the MILLROCK Ambient Counter on your front counter and plug it in. Start maximizing your opportunities for non-refrigerated food sales with this unique Ambient Counter case.

MILLROCK Display Cases

Deliver unparalleled merchandising • Match your interior design • Enhance your store image • Boost impulse buying & rapid transactions

Models



405 West Street ■ West Bridgewater, MA 02379 ■ p:800.645.7625 ■ f:617.687.7700
e:sales@millrock.com ■ www.millrock.com ■ www.GrowYourBrand.com

© 2000 - 2005 Modular Brand Group, LLC All Rights Reserved. Millrock is a division of Modular Brand Group, LLC
Continual product improvement may necessitate changes in specifications without notice

DISPLAY CASES
Ambient Counter

Rev.082105

DISPLAY CASES

Ambient Counter

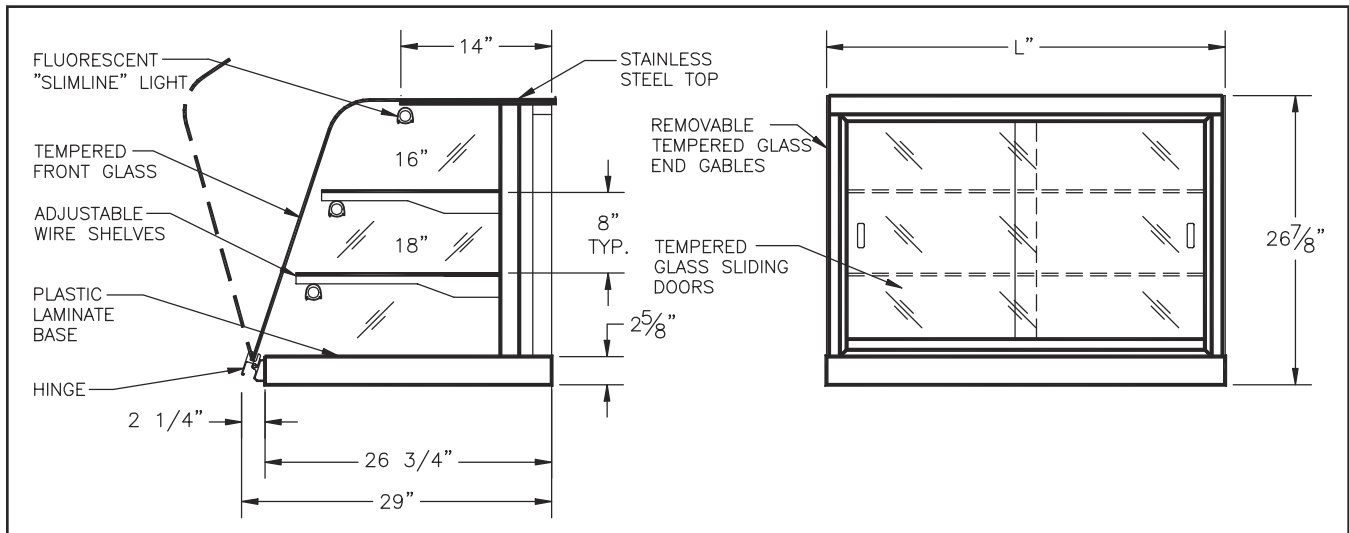

OPTIONS

- ◆ **Custom Finishes** - We welcome the opportunity to match designer finishes with any stone, hardwood, & metal for the front, top or sides of your MILLROCK.
- ◆ **Stone** - Granite top & interior floor
- ◆ **Mirrored Doors** - One way mirrored glass rear doors
- ◆ **Security Kit** - Locking rear doors & front glass
- ◆ **Product ID Kit** - Sign holders, (2) Clear full shelf 1 1/4" H. ticket strips & (3) floor easel clips
- ◆ **Shelving Option** - Stainless Steel or tempered glass shelves
- ◆ **Hardware Colors** - Powder-coated front hinge, shelf supports & lighting valance
- ◆ **Custom Sizes** - Available in custom depth and height

TECH SPECS

- ◆ 24" Only – Choose Left or Right hinged glass rear door (37 & 48 slide)
- ◆ 8' long cord with plug
- ◆ Meets All Electrical & Sanitation Requirements for USA & Canada including CSA, ETL, NSF, UL, & CRMA. Certified by ETL.
- ◆ Warranty – 1 year parts and labor

MODEL	DIMENSIONS (INCHES) length - depth - height	ELECTRICAL volts/phase/hertz - amps.	SHIPPING WEIGHT / VOLUME lbs. / cu. ft.
A24C	24 - 29 - 26 7/8	120/1/60 - 1.0	165 / 20.0
A37C	37 - 29 - 26 7/8	120/1/60 - 1.0	205 / 29.0
A48C	48 - 29 - 26 7/8	120/1/60 - 1.0	245 / 37.5

405 West Street ■ West Bridgewater, MA 02379 ■ p:800.645.7625 ■ f:617.687.7700
 e:sales@millrock.com ■ www.millrock.com ■ www.GrowYourBrand.com

© 2000 - 2003 Modular Brand Group, LLC All Rights Reserved. Millrock is a division of Modular Brand Group, LLC

Continual product improvement may necessitate changes in specifications without notice

Rev.082105