

DISPLAY CASES

Ambient Shorty

MILLROCK



FEATURES

- ◆ **Bent Front Glass** - Unobstructed product view.
- ◆ **Lights For Every Shelf** - 3 Slim-line fluorescent fixtures illuminate all products, no shadows & great visibility, light shield & impact sleeve included
- ◆ **Mirrored Side Walls** - unobstructed glass at counter height for optimal product visibility from any vantage point.
- ◆ **Any Exterior Finish** - select any standard color, pattern or wood grain plastic laminate
- ◆ **Mirrored Rear Doors** - Tempered glass, bypass sliding, easy close & lift out, one-way mirrored.
- ◆ **Glass Shelves** - (2) Tiers 3/8" tempered glass shelves
- ◆ **Finished Top** - integrate the top with your countertop
- ◆ **Bottom Shelf** - White laminate for brilliant display
- ◆ **Front Toe-kick** - Seamless integration with companion MILLROCK Café Modules
- ◆ **Plug & 8' Cord Included** - 110v. Plug in and start selling!
- ◆ **Meets All Electrical & Sanitation Requirements for USA & Canada** including CSA, ETL, NSF, UL, & CRMA. Certified by CSA & ETL.
- ◆ **Superior Warranty** - 1 year parts and labor

Models

AS33

AS41

Unrivalled Non-Refrigerated Counter

The MILLROCK™ Ambient Shorty™ is the ultimate addition to any counter. Until now the shorty series was only available to designers. The Shorty delivers uninterrupted counter design lines with the added appeal of bent glass. The Ambient Shorty showcases your non-refrigerated products commanding premium sell prices. Professional counter displays cookies, biscotti, bagels, muffins, scones, and non-dairy cakes that cascade from the counter nearly to the floor. The low countertop height provides totally unobstructed customer interaction and impulse shopping displays opportunity.

Create a premier first impression with the MILLROCK Ambient Shorty! Bent non-glare glass, mirrored interior and individual lighting on every shelf provide outstanding product presentation. The one-way vision mirror on the doors allows your operator to clearly view all products and easily assist customers. Match your counter top and front with the choice of any laminate, stone, or wood finish. Incomparable display height for children.

MILLROCK Display Cases

Deliver unparalleled merchandising • Match your interior design • Enhance your store image • Boost impulse buying & rapid transactions

DISPLAY CASES Ambient Shorty

405 West Street ■ West Bridgewater, MA 02379 ■ p:800.645.7625 ■ f:617.687.7700
e:sales@millrock.com ■ www.millrock.com ■ www.GrowYourBrand.com

© 2000 - 2005 Modular Brand Group, LLC All Rights Reserved. Millrock is a division of Modular Brand Group, LLC
Continual product improvement may necessitate changes in specifications without notice

Rev.082105

DISPLAY CASES

Ambient Shorty

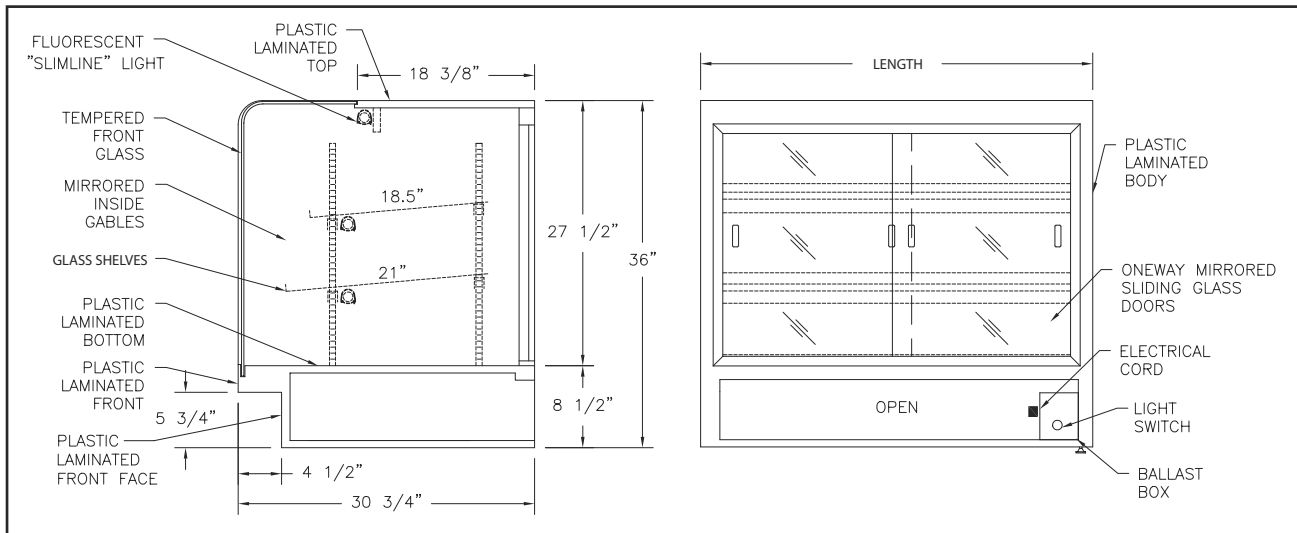

OPTIONS

- ◆ **FREE ADA Compliance** - We're proud to offer this model to comply as an Americans with Disabilities Act service point lowered to 34" height.
- ◆ **Custom Finishes** - We welcome the opportunity to match designer finishes with any stone, hardwood, & metal for the front, top or sides of your MILLROCK.
- ◆ **Stone** - Granite top & interior floor
- ◆ **Storage pedestal** - Raise the Shorty to 53" height with a 17" storage cabinet base for eye level display.
- ◆ **Security Kit** - Locking rear doors
- ◆ **Casters** - Easy cleaning, semi-mobile placement, and delivery. Only available at time of order. Add 1/2" to height.
- ◆ **Product ID Kit** - Sign holders, (4) Clear full shelf 1 1/4" H. ticket strips & (6) floor easel clips
- ◆ **FREE Shelving Option** - Wire or Stainless steel
- ◆ **Hardware Colors** - Powder-coated front hinge, shelf supports & lighting valance
- ◆ **Custom Sizes** - Available in custom depth and height

TECH SPECS

- ◆ 8' long cord with plug
- ◆ Meets All Electrical & Sanitation Requirements for USA & Canada including CSA, ETL, NSF, UL, & CRMA. Certified by ETL.
- ◆ Warranty - 1 year parts and labor

MODEL	DIMENSIONS (INCHES) length - depth - height	ELECTRICAL volts/phase/hertz - amps.	SHIPPING WEIGHT / VOLUME lbs. / cu. ft.
AS33	32½ - 30¾ - 36	120/1/60 - 2.4	270 / 47.0
AS41	40¾ - 30¾ - 36	120/1/60 - 2.4	295 / 55.0

405 West Street ■ West Bridgewater, MA 02379 ■ p:800.645.7625 ■ f:617.687.7700
 e:sales@millrock.com ■ www.millrock.com ■ www.GrowYourBrand.com

© 2000 - 2005 Modular Brand Group, LLC All Rights Reserved. Millrock is a division of Modular Brand Group, LLC

Continual product improvement may necessitate changes in specifications without notice

Rev.082105