

DISPLAY CASES

Grab N' Go Frontline

MILLROCK



FEATURES

- ◆ **Self Serve Refrigeration** - Unobstructed product view with superior air screen system easily maintains product temperature at 38 degrees
- ◆ **Rear Loading** - Stainless steel doors allow the operator to easily maintain stocking levels at all times
- ◆ **Lights For Every Shelf** - 3 Slim-line fluorescent fixtures illuminate all products, no shadows & great visibility, light shield & impact sleeve included
- ◆ **Any Exterior Finish** - select any standard color, pattern or wood grain plastic laminate
- ◆ **Stainless Steel Shelves** - Superior presentation and unmatched durability for professional foodservice display
- ◆ **Plug & 8' Cord Included** - 110v. Plug in and start selling!
- ◆ **Meets All Electrical & Sanitation Requirements for USA & Canada** including CSA, ETL, NSF, UL, & CRMA. Certified by CSA & ETL.
- ◆ **Superior Warranty** - 1 year parts and labor / 5 years compressor.

Self Service, Front & Center!

...is where the MILLROCK Grab N' Go Frontline commands impulse sales. The curved profile matches all MILLROCK curved glass display cases creating a host of revenue opportunities from those in line while you serve the customer. Rear loading Stainless steel doors allow the operator to easily maintain stocking levels at all times.

The fit and finish of the MILLROCK Grab N' Go Frontline is spectacular! Curved sides, mirrored interior and individual lighting on 3 tiers of display provide outstanding product presentation. Our standard options include four sizes and choice of any laminate or wood finish.

MILLROCK Display Cases

Deliver unparalleled merchandising • Match your interior design • Enhance your store image • Boost impulse buying & rapid transactions

DISPLAY CASES
Grab N' Go Frontline

Models



405 West Street ■ West Bridgewater, MA 02379 ■ p:800.645.7625 ■ f:617.687.7700
e:sales@millrock.com ■ www.millrock.com ■ www.GrowYourBrand.com

© 2000 - 2005 Modular Brand Group, LLC All Rights Reserved. Millrock is a division of Modular Brand Group, LLC
Continual product improvement may necessitate changes in specifications without notice

Rev.082105

DISPLAY CASES

Grab N' Go Frontline

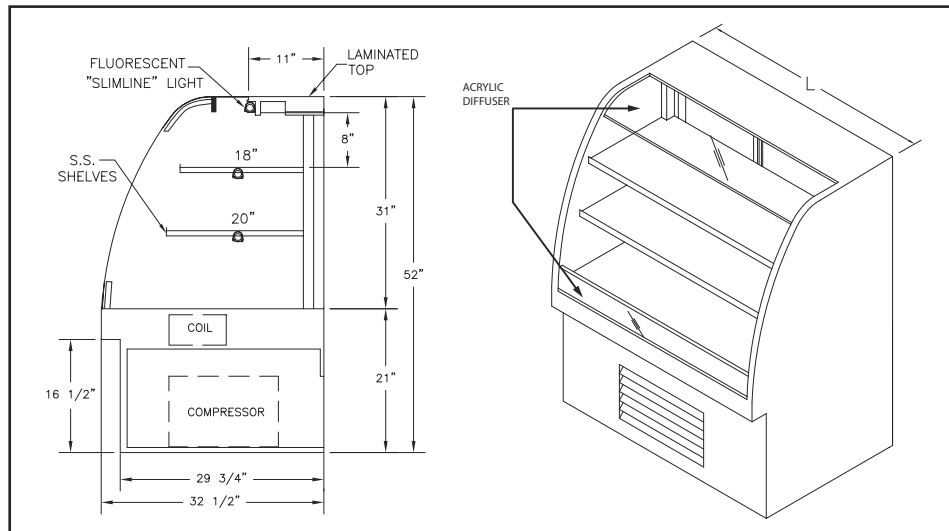

OPTIONS

- ◆ **Custom Finishes** - We welcome the opportunity to match designer finishes with any stone, hardwood, & metal for the front, top or sides of your MILLROCK.
- ◆ **FREE Side panel option** - Solid with mirrored interior
- ◆ **Security Kit** - Locking front panel for after hours theft deterrence
- ◆ **Casters** - Easy cleaning, semi-mobile placement, and delivery. Only available at time of order. Add 1/2" to height.
- ◆ **Product ID Kit** - Sign holders, (4) Clear full shelf 1 1/4" H. ticket strips & (6) floor easel clips
- ◆ **FREE Shelving Option** - Glass or Wire in lieu of Stainless Steel
- ◆ **Hardware Colors** - Powder-coated front hinge, shelf supports & lighting valance
- ◆ **Custom Sizes** - Available in custom length, depth & height
- ◆ **Remote Refrigeration** - Excludes refrigeration system

TECH SPECS

- ◆ **Laboratory Tested** - Every MILLROCK undergoes a 24 hour endurance test with 181 point quality control inspection before shipment
- ◆ **Operating Temp.** Refrigerated side is factory calibrated to 38° F.
- ◆ **8' long cord with plug** MILLROCK™ Cases are designed to operate under normal store conditions less than 75° F (24° C) with less than 50% Relative Humidity
- ◆ **Hot gas evaporator pan**
- ◆ **Refrigerant is environmentally friendly R22**
- ◆ **Meets All Electrical & Sanitation Requirements for USA & Canada** including CSA, ETL, NSF, UL, & CRMA. Certified by ETL.
- ◆ **Warranty** - 1 year parts and labor / 5 years compressor.

MODEL	DIMENSIONS (INCHES) length - depth - height	ELECTRICAL volts/phase/hertz - amps.	COMPRESSOR (hp)	SHIPPING WEIGHT / VOLUME lbs. / cu. ft.
GF38	38 - 32.5 - 52	120/1/60 - 12	1/3	425 / 55
GF50	50 - 32.5 - 52	120/1/60 - 12	1/2	500 / 69
GF62	62 - 32.5 - 52	120/1/60 - 12	1/2	600 / 84
GF74	74 - 32.5 - 52	120/1/60 - 12	1/2	700 / 102

405 West Street ■ West Bridgewater, MA 02379 ■ p:800.645.7625 ■ f:617.687.7700
 e:sales@millrock.com ■ www.millrock.com ■ www.GrowYourBrand.com

© 2000 - 2005 Modular Brand Group, LLC All Rights Reserved. Millrock is a division of Modular Brand Group, LLC

Continual product improvement may necessitate changes in specifications without notice

Rev.082105