

MODULAR CAFÉ Barista Center 60"

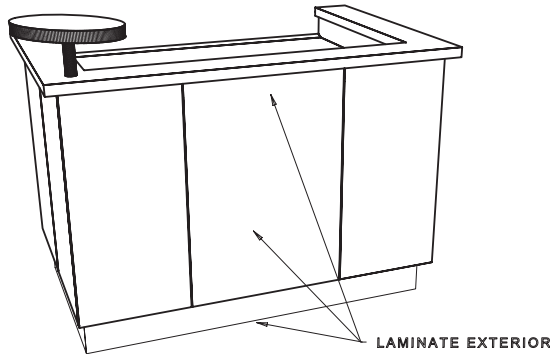

Model #:MBC60



FRONT CUSTOMER PERSPECTIVE VIEW

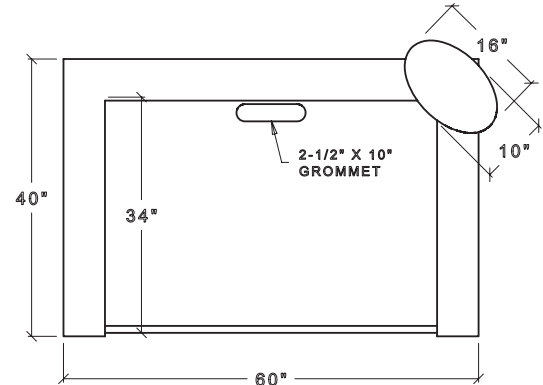

TOP PLAN VIEW

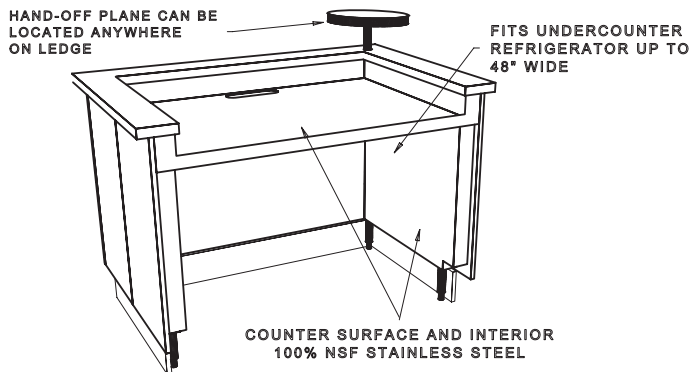

REAR OPERATOR PERSPECTIVE VIEW

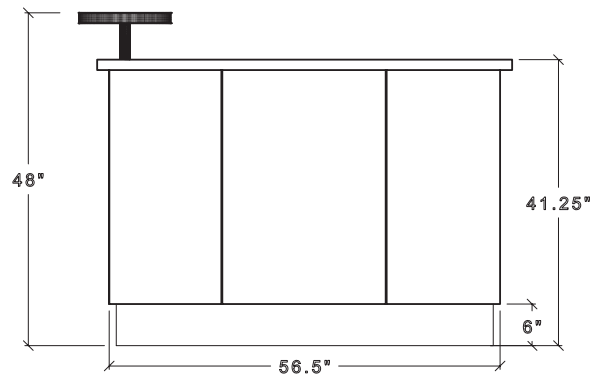

FRONT ELEVATION CUSTOMER VIEW

500lbs. with top [weight excludes skid or crating]

FEATURES

- ◆ Exterior is removable laminate finish panels, integrated transaction ledge, and raised hand-off plane. Hand-off can be mounted any place on ledge.
- ◆ Accommodates all espresso machines including super-automatics and four group
- ◆ Open underneath for under-counter refrigerators up to 48" wide (Order with ADA low casters).
- ◆ Stainless Steel 16 gauge 304 series counter tops with Spill-proof™ edges, integrated coved corner backsplash and raised 2-1/2" x 10" plumbing and electrical grommet hole.
- ◆ Integrated waterproof metal legs are fully adjustable
- ◆ Removable toekick is marine grade plywood with black laminate finish.

405 West Street ■ West Bridgewater, MA 02379 ■ p:800.645.7625 ■ f:617.687.7700
e:sales@millrock.com ■ www.millrock.com

© 2000 - 2006 Modular Brand Group, LLC All Rights Reserved. Millrock is a division of Modular Brand Group, LLC
Continual product improvement may necessitate changes in specifications without notice

