

Model #:MES30 (UCR27) / MES52 (UCR48)

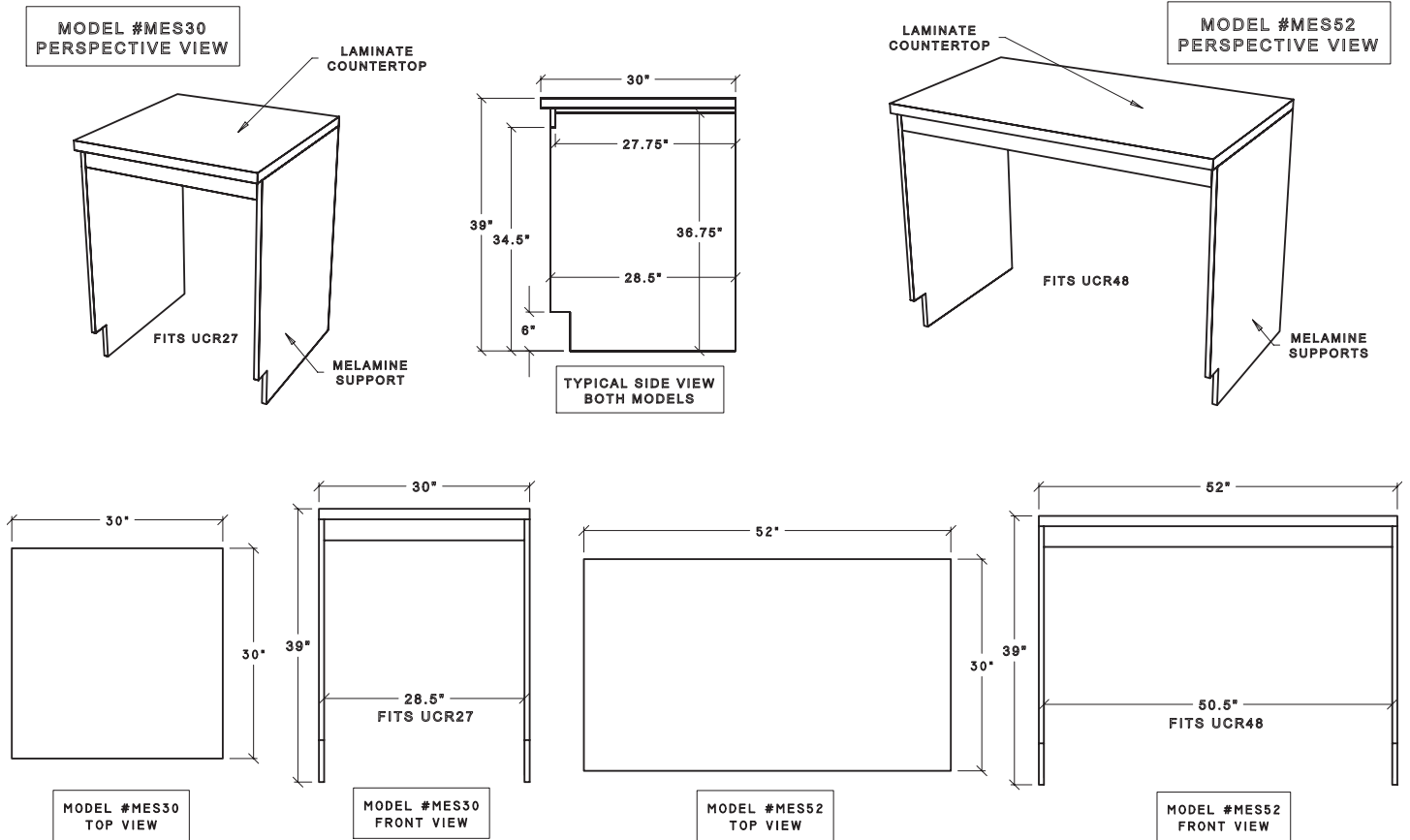

Weight: MES30 weighs 75 lbs; MES52 weighs 105 lbs (excluding crate or skid)

FEATURES

- ◆ Countertop with plastic laminate of your choice.
- ◆ Create a professional finished opening for under counter equipment such as: refrigerator, freezer, dishwasher, ice machine, ingredient bin, bus cart, or ice cart
- ◆ Open back for easy utility connections
- ◆ Provides a sealed left and right panel to adjacent modules
- ◆ MES30 designed to fit most 1 door refrigerators & MES52 Designed to fit most 2 door undercounter refrigerators
- ◆ Customer must supply equipment make & model for desired undercounter equipment prior to fabrication

Options:

- ◆ FREE Sized to order shorter length
- ◆ Sized for increased width and height available
- ◆ Integrally welded 16 gauge 304 series stainless steel Spill-proof™ counters.
- ◆ Stainless steel modular base cabinet construction.

405 West Street ▪ W. Bridgewater, MA 02379 ▪ p:800.645.7625 ▪ f:617.687.7700
 e:sales@millrock.com ▪ www.millrock.com