

MODULAR CAFÉ
Cashier Module 24" Drop Well

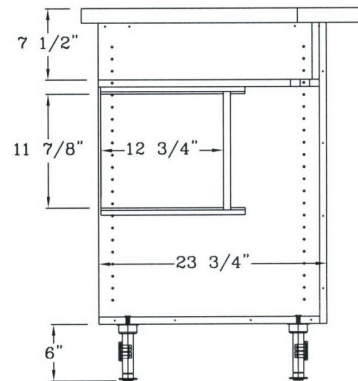

Model #:MCM24DW

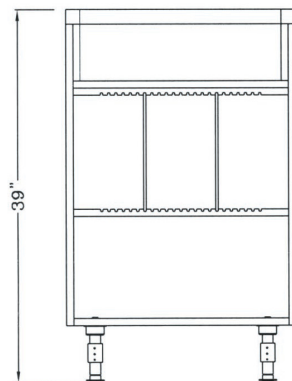
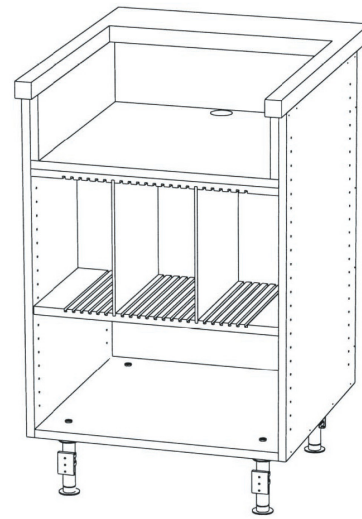
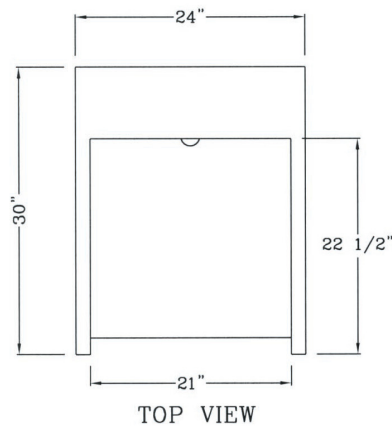

FRONT VIEW

SIDE SECTION

115lbs. with top [weight excludes skid or crating]

FEATURES

- ◆ Designed for your full-size cash register system with integrated cash drawer (like NCR)
- ◆ Black melamine interior with built-in adjustable dividers for bag / tissue storage
- ◆ Countertop with plastic laminate of your choice.
- ◆ Integrated waterproof metal legs are fully adjustable
- ◆ Removable toekick is marine grade plywood with black laminate finish.

Options:

- ◆ Integrally welded 16 gauge 304 series stainless steel Spill-proof™ counters.
- ◆ Stainless steel modular base cabinet construction.

405 West Street ■ West Bridgewater, MA 02379 ■ p:800.645.7625 ■ f:617.687.7700
e:sales@millrock.com ■ www.millrock.com

© 2000 - 2006 Modular Brand Group, LLC All Rights Reserved. Millrock is a division of Modular Brand Group, LLC
Continual product improvement may necessitate changes in specifications without notice

