

MODULAR CAFÉ Trash Cart 24"

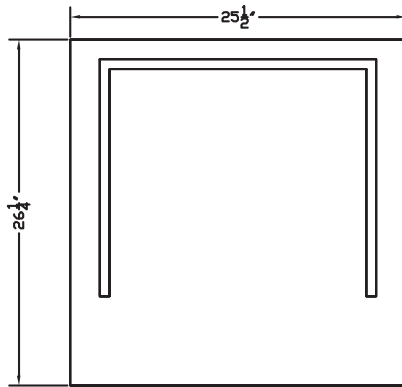

Model #:MTC24



TOP VIEW

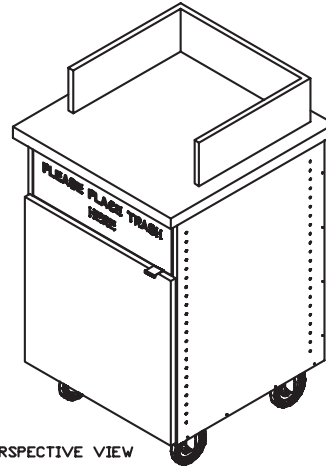

PERSPECTIVE VIEW

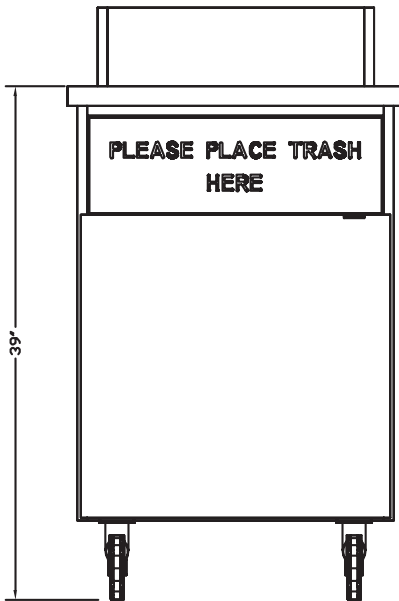

SIDE VIEW

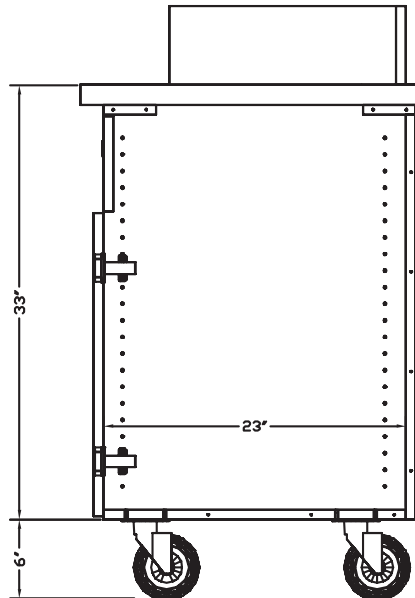

SIDE SECTION

150lbs. with top [weight excludes skid or crating]

FEATURES

- ◆ Plastic laminate door
- ◆ Black melamine interior
- ◆ Includes top swinging trash opening
- ◆ Reversible door swing
- ◆ Accommodates trash containers up to 22" Width x 22" Length x 22"Height (not included)
- ◆ Countertop with a plastic laminate of your choice
- ◆ Heavy duty locking casters standard, legs with toe kick are optional

Options:

- ◆ Integrally welded 16 gauge 304 series stainless steel Spill-proof™ counters.
- ◆ Stainless steel modular base cabinet construction.

405 West Street • W. Bridgewater, MA 02379 • p:800.645.7625 • f:617.687.7700
e:sales@millrock.com • www.millrock.com

© 2000 - 2006 Modular Brand Group, LLC All Rights Reserved. Millrock is a division of Modular Brand Group, LLC • Investigation of local health and building codes is recommended prior to placing your order • Continual product improvement may necessitate changes in specifications without notice.

Rev.041806